

Wooden fronts, wide and narrow alu frames – TIP-ON

Web code – click on the code or enter it in the Product Configurator

DQHS7Y

Planning

Drilling position – system screws

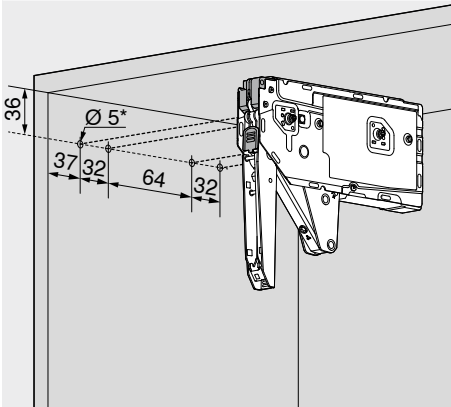

* Drilling depth 11.5 mm

Drilling position – chipboard screws

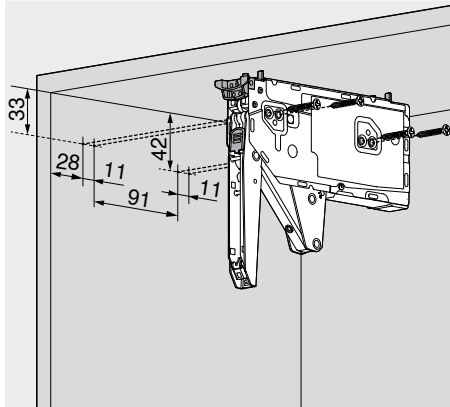

4 x chipboard screws Ø 4 x 35 mm

Space requirement

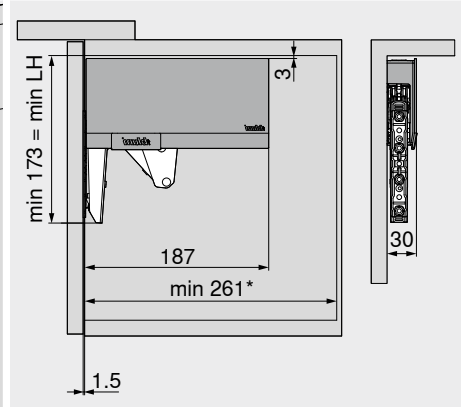

LH Internal cabinet height
* Min. 261 mm with visible wall hanging bracket

Space requirement – cornice | crown

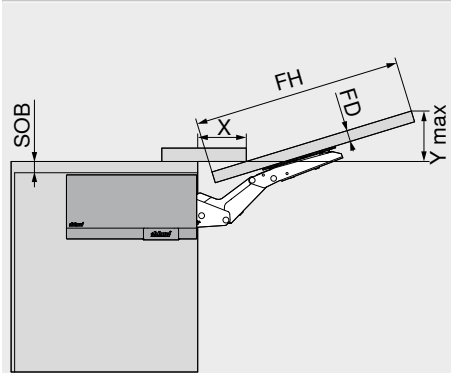

Space requirement (mm)

At max. opening angle
Y = FH x 0.29 + FD – SOB

FD (mm)	16	19	22	26	28	-
X (mm)	68	57	47	33	27	-

FD Front thickness
FH Front height
SOB Top panel thickness

Minimum gap MF

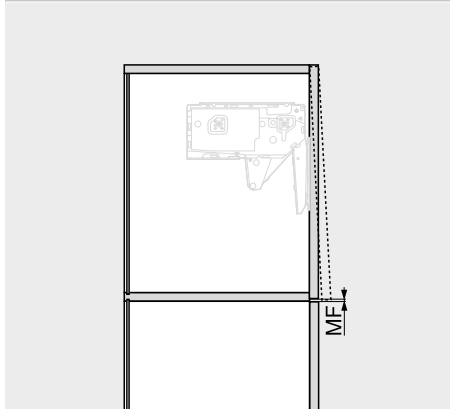

MF Minimum gap
2 mm

Narrow alu frames

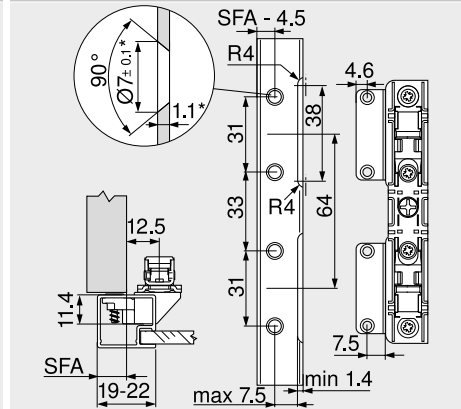

For frame width 19 mm, a side front overlay SFA of 11–18 mm is possible
* When changing material thickness, adjust the assembly dimensions accordingly

Front assembly – wooden fronts and wide alu frames

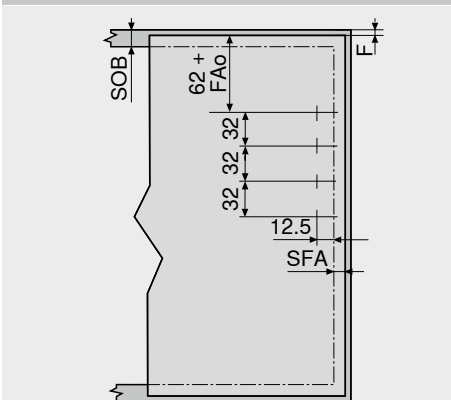

Use 4 chipboard screws (609.1x00) for wooden fronts
Use 4 counter sunk self tapping screws (660.0950) for wide alu frames
F Gap
FAo Upper front overlay
Max. 25.4 mm
SFA Front overlay of the side panel
SOB Top panel thickness

Front assembly – narrow alu frames

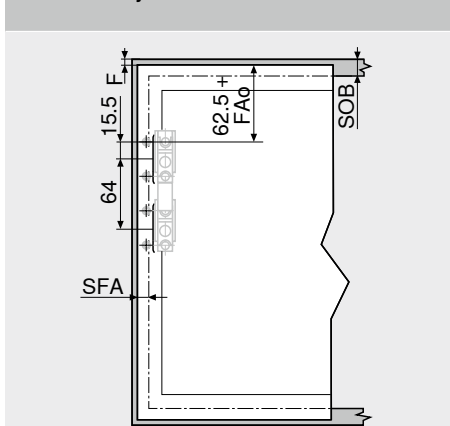

F Gap
FAo Upper front overlay
Max. 25.4 mm
SFA Front overlay of the side panel
SOB Top panel thickness

Reference pages

Overview	45
TIP-ON 956x	52
Planning – positioning system – chipboard screws	48
Fixing system for thin fronts – EXPANDO T	596
Assembly recommendation and limitation of liability – EXPANDO T	597
Blum services	602
More technical details	708

AVENTOS HK top

Short URL
www.blum.com/i014

Assembly, removal and adjustment

Short URL
www.blum.com/a170

